



A division of CIRCOR International, Inc.

DV1 Series

2-way Diaphragm Valves



The DV1 Series Diaphragm Valves are totally free of springs, bellows, packing, o-rings and lubricants in the process wetted area. Metal-to-metal seals to atmosphere ensure that there is no adsorption of undesirable elements into the flow stream. Elgiloy® diaphragms insure the utmost in corrosion resistance and life span.

Features & Benefits

2-way on/off control

Metal-to-metal seals to atmosphere

Wide variety of materials for virtually all applications

No o-rings, springs, or lubricant in flow

Very low internal volume (0.01cc)

Manual ¼+ turn or pneumatic actuation

Pressures from vacuum to 3600 psig

Optimal diaphragm design provides for long cycle life

40µ sintered stainless steel inlet filter on air port of pneumatic actuators extends life of actuator

diaphragm valves

DV1 Series

Specifications

Manual 1/4+ Turn Valves



| | |
|----------------------------------|---|
| BODY | 316L stainless steel, Monel® and Hastelloy® C |
| SEATS | PCTFE (Kel-F®), Polyimide, Tefzel® and PEEK™ |
| DIAPHRAGMS | Elgiloy® AMS 5876 |
| WORKING TEMPERATURE RANGE | -40° to +500° F (-40° C to +260° C) |
| WORKING PRESSURE RANGE | Vacuum (50 torr) to 3600 psig (248 BAR) |
| ORIFICE SIZE | 0.110" |
| FLOW CAPACITY | 0.17 Cv |
| LOW CAVITY VOLUME | 0.01cc |
| LEAKAGE | 1 × 10 ⁻⁹ cc/sec helium (inboard) |
| LIFE CYCLES | In excess of 5,000,000 cycles @ 250 psig |

Operating Pressures

| | |
|---------------------------|-------------------------------|
| OPERATING PRESSURE | Vacuum (50 torr) to 3600 psig |
| PROOF PRESSURE | 7200 psig |
| BURST PRESSURE | 14,400 psig |

Operating Temperatures

| SEAT MATERIAL | 1/4+ TURN TEMPERATURE |
|-------------------|-----------------------|
| Tefzel® | -40° F to +140° F |
| PCTFE/Kel-F® | -40° F to +175° F |
| Polyimide/Vespel® | -40° F to +400° F |
| PEEK™ | -40° F to +500° F |

Note: Brass bodies are limited to 140° F

DV1
Pressure Drop vs Flow
500 psig Process Pressure

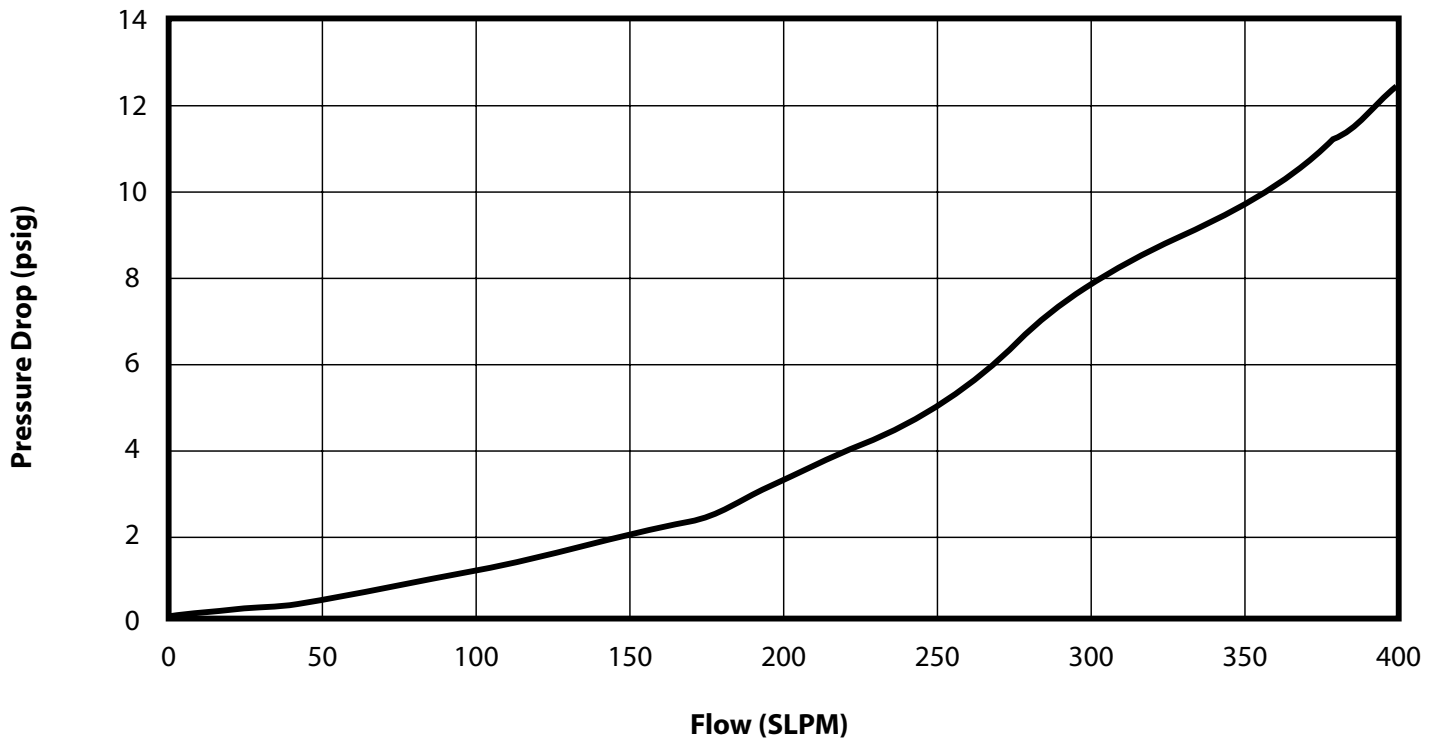

Note: Flow chart applies to all 2-way DV1 Series diaphragm valves

DV1 Series

Materials of Construction

Manual 1/4+ Turn Valves

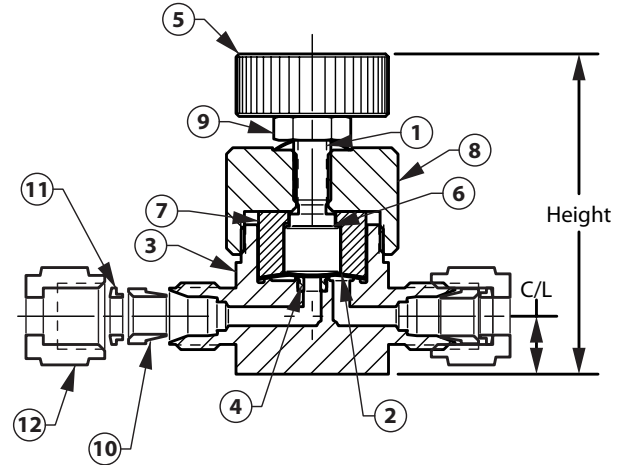
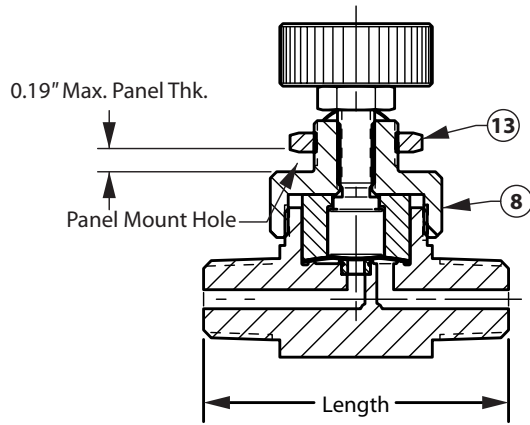

| # | PART | MATERIALS |
|----|--------------------|---|
| 1 | Stem | 17-4PH stainless steel, condition H900 |
| 2 | Diaphragm* | Elgiloy® |
| 3 | Body* | 316L stainless steel, Monel®, brass, Hastelloy® C |
| 4 | Seat* | PCTFE (Kel-F®), Polyimide (Vespel®), Tefzel®, PEEK™ |
| 5 | Handle | Stainless steel |
| 6 | Thrust plug | Brass |
| 7 | Diaphragm retainer | 316 stainless steel |
| 8 | Bonnet | 316L stainless steel, Monel®, brass, Hastelloy® C |
| 9 | Handle nut | 18-8 stainless steel |
| 10 | Front ferrule* | 316L stainless steel, Monel®, brass, Hastelloy® C |
| 11 | Rear ferrule | 316L stainless steel, Monel®, brass, Hastelloy® C |
| 12 | Nut | 316L stainless steel, Monel®, brass, Hastelloy® C |
| 13 | Panel-mount nut | 316L stainless steel, Monel®, brass, Hastelloy® C |

*Wetted components

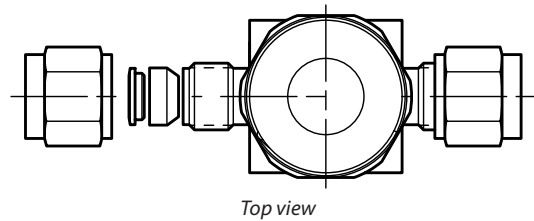

Dimensions

Manual 1/4+ Turn Valves

| END CONNECTION | LENGTH | HEIGHT | HANDLE RADIUS | C/L CENTER LINE | PANEL MOUNT HOLE | PANEL MOUNT THICK |
|-------------------|--------|---------|---------------|-----------------|------------------|-------------------|
| 1/4" MNPT | 2.00" | 2.44" | .90" | .38" | .57" | .19" |
| 1/4" FNPT | 2.00" | 2.44" | .90" | .38" | .57" | .19" |
| 1/8" Gyrolok® | 1.71" | 2.44" | .90" | .38" | .57" | .19" |
| 1/4" Gyrolok® | 1.87" | 2.44" | .90" | .38" | .57" | .19" |
| 1/4" NPT Extended | 3.15" | 2.44" | .90" | .38" | .57" | .19" |
| 6mm Gyrolok® | 47.5mm | 61.98mm | 22.86mm | 9.65mm | 14.48mm | 4.83mm |
| 8mm Gyrolok® | 47.5mm | 61.98mm | 22.86mm | 9.65mm | 14.48mm | 4.83mm |

DV1 Series

Specifications

Pneumatic Actuated Valves



| | |
|----------------------------------|--|
| BODY | 316L stainless steel, Monel® and Hastelloy® C |
| SEATS | PCTFE (Kel-F®), Polyimide, Tefzel® and PEEK™ |
| DIAPHRAGMS | Elgiloy® AMS 5876 |
| WORKING TEMPERATURE RANGE | -40° to +500° F (-40° C to +260° C) |
| WORKING PRESSURE RANGE | Vacuum (50 torr) to 3600 psig (248 BAR) |
| ORIFICE SIZE | 0.110" |
| FLOW CAPACITY | 0.17 Cv |
| LOW CAVITY VOLUME | 0.01cc |
| LEAKAGE | 1 × 10 ⁻⁹ cc/sec helium (inboard) |
| PNEUMATIC ACTUATOR | Anodized aluminum standard (other materials optional) 40μ sintered stainless steel inlet air filter |
| LIFE CYCLES | In excess of 5,000,000 cycles @ 250 psig |

Operating Pressures Ratings

| | SMALL DIAMETER | MEDIUM DIAMETER | LARGE DIAMETER |
|-------------------------------|------------------------------|------------------------------|-------------------------------|
| VALVE WORKING PRESSURE | Vacuum (50 torr) to 500 psig | Vacuum (50 torr) to 800 psig | Vacuum (50 torr) to 3600 psig |
| VALVE PROOF PRESSURE | 1000 psig | 1600 psig | 7200 psig |
| VALVE BURST PRESSURE | 2000 psig | 3600 psig | 14,400 psig |

Operating Temperatures

| SEAT MATERIAL | TEMPERATURE |
|-------------------|-------------------|
| Tefzel® | -40° F to +140° F |
| PCTFE/Kel-F® | -40° F to +175° F |
| Polyimide/VespeI® | -40° F to +400° F |
| PEEK™ | -40° F to +400° F |

Note: Brass bodies are limited to 140° F

Air Actuation Pressure Requirements (psig nominal)

| PRESSURE | SMALL DIAMETER | MEDIUM DIAMETER | LARGE DIAMETER |
|------------------------------------|--|--|--|
| Valve Operating Pressure | Vacuum (50 torr) to 500 psig | Vacuum (50 torr) to 800 psig | Vacuum (50 torr) to 3600 psig |
| Actuation Pressure Normally Closed | 19 psig (0–250 psig process pressure) | 14 psig (0–250 psig process pressure) | 21 psig (251–500 psig process pressure) |
| Actuation Pressure Normally Open | 39 psig (251–500 psig process pressure) | 33 psig (501–800 psig process pressure) | 50 psig (0–3600 psig process pressure) |
| | 36 psig (500 psig process pressure) | 32 psig (800 psig process pressure) | N/A |

Note: Actuation/Pressure Curves available on the web at www.gore.com

Dimensions

Pneumatic Actuated Valves

Pneumatic Small Diameter Actuator

| END CONNECTION | LENGTH | HEIGHT | ACTUATOR DIAMETER | C/L CENTER LINE |
|-----------------|--------|---------|-------------------|-----------------|
| ¼" MNPT | 2.00" | 2.75" | 1.31" | .38" |
| ¼" FNPT | 2.00" | 2.75" | 1.31" | .38" |
| ⅛" Gyrolok® | 1.71" | 2.75" | 1.31" | .38" |
| ¼" Gyrolok® | 1.87" | 2.75" | 1.31" | .38" |
| ¼" NPT Extended | 3.15" | 2.75" | 1.31" | .38" |
| 6mm Gyrolok® | 47.5mm | 69.85mm | 33.27mm | 9.65mm |
| 8mm Gyrolok® | 47.5mm | 69.85mm | 33.27mm | 9.65mm |

Pneumatic Medium Diameter Actuator

| END CONNECTION | LENGTH | HEIGHT | ACTUATOR DIAMETER | C/L CENTER LINE |
|-----------------|--------|---------|-------------------|-----------------|
| ¼" MNPT | 2.00" | 2.75" | 1.56" | .38" |
| ¼" FNPT | 2.00" | 2.75" | 1.56" | .38" |
| ⅛" Gyrolok® | 1.71" | 2.75" | 1.56" | .38" |
| ¼" Gyrolok® | 1.87" | 2.75" | 1.56" | .38" |
| ¼" NPT Extended | 3.15" | 2.75" | 1.56" | .38" |
| 6mm Gyrolok® | 47.5mm | 69.85mm | 39.62mm | 9.65mm |
| 8mm Gyrolok® | 47.5mm | 69.85mm | 39.62mm | 9.65mm |

Pneumatic Large Diameter Actuator

| END CONNECTION | LENGTH | HEIGHT | ACTUATOR DIAMETER | C/L CENTER LINE |
|-----------------|--------|---------|-------------------|-----------------|
| ¼" MNPT | 2.00" | 3.25" | 2.36" | .38" |
| ¼" FNPT | 2.00" | 3.25" | 2.36" | .38" |
| ⅛" Gyrolok® | 1.71" | 3.25" | 2.36" | .38" |
| ¼" Gyrolok® | 1.87" | 3.25" | 2.36" | .38" |
| ¼" NPT Extended | 3.15" | 3.25" | 2.36" | .38" |
| 6mm Gyrolok® | 47.5mm | 82.55mm | 59.94mm | 9.65mm |
| 8mm Gyrolok® | 47.5mm | 82.55mm | 59.94mm | 9.65mm |

DV1 Series

Materials of Construction

Pneumatic Actuated Valves

Normally Closed

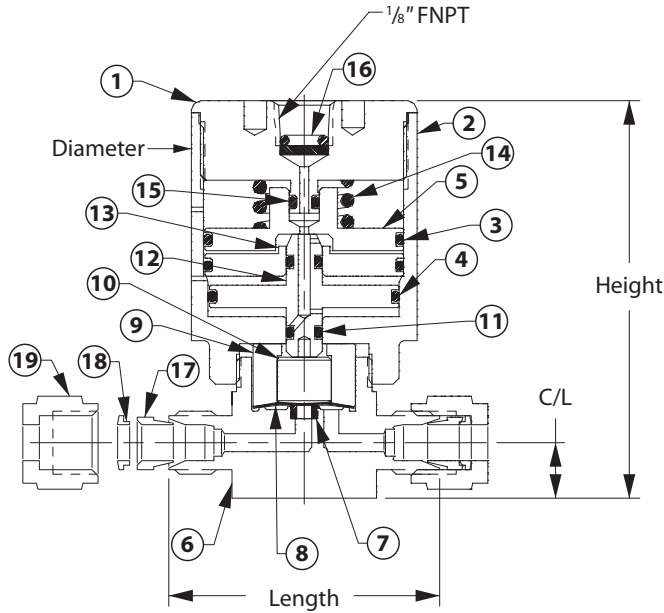

See dimension on previous page.

| # | PART | MATERIALS |
|----|--------------------|---|
| 1 | Housing cap | Aluminum, 316L stainless steel, Monel® & Hastelloy® C |
| 2 | Housing | Aluminum, 316L stainless steel, Monel® & Hastelloy® C |
| 3 | O-rings | Viton® |
| 4 | O-rings | Viton® |
| 5 | Upper piston | Brass |
| 6 | Body* | 316L stainless steel, brass, Monel® & Hastelloy® C |
| 7 | Seat* | PCTFE (Kel-F®), Polyimide (VespeI®), Tefzel®, PEEK™ |
| 8 | Diaphragm* | Elgiloy® |
| 9 | Diaphragm retainer | 316 stainless steel |
| 10 | Thrust plug | Brass |
| 11 | O-ring | Viton® |
| 12 | Lower piston | Brass |
| 13 | Chamber separator | Brass |
| 14 | Spring | NISPAN |
| 15 | O-ring | Viton® |
| 16 | Sintered filter | 316 stainless steel, 40µ |
| 17 | Front ferrule* | 316L stainless steel, brass, Monel® & Hastelloy® C |
| 18 | Rear ferrule | 316L stainless steel, brass, Monel® & Hastelloy® C |
| 19 | Nut | 316L stainless steel, brass, Monel® & Hastelloy® C |

*Wetted components

Normally Open

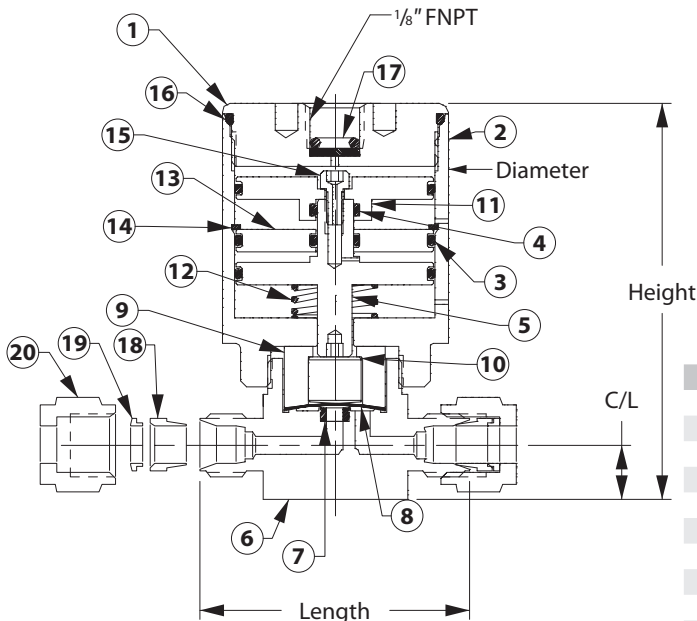

See dimension on previous page.

| # | PART | MATERIALS |
|----|--------------------|---|
| 1 | Housing cap | Aluminum, 316L stainless steel, Monel® & Hastelloy® C |
| 2 | Housing | Aluminum, 316L stainless steel, Monel® & Hastelloy® C |
| 3 | O-rings | Viton® |
| 4 | O-rings | Viton® |
| 5 | Piston | Brass |
| 6 | Body* | 316L stainless steel, brass, Monel® & Hastelloy® C |
| 7 | Seat* | PCTFE (Kel-F®), Polyimide (VespeI®), Tefzel®, PEEK™ |
| 8 | Diaphragm* | Elgiloy® |
| 9 | Diaphragm retainer | 316 stainless steel |
| 10 | Thrust plug | Brass |
| 11 | Upper piston | Brass |
| 12 | Spring | 302 stainless steel |
| 13 | Chamber separator | Brass |
| 14 | Retaining ring | 302 stainless steel |
| 15 | Cap screw | Alloy steel |
| 16 | O-ring | Viton® |
| 17 | Sintered filter | 316 stainless steel, 40µ |
| 18 | Front ferrule | 316L stainless steel, brass, Monel® & Hastelloy® C |
| 19 | Rear ferrule | 316L stainless steel, brass, Monel® & Hastelloy® C |
| 20 | Nut | 316L stainless steel, brass, Monel® & Hastelloy® C |

*Wetted components

DV1 Series

How to Order

DV1- 1 C 2 5 C G4 G4 H 0 H

BODY MATERIAL

- 1 316L stainless steel (standard)
- 2 Brass
- 3 Nickel-plated brass
- 4 Monel®
- 6 Hastelloy® C

ACTUATION METHOD

- M Manual ¼+ turn
- C Air actuated—normally closed
- O Air actuated—normally open

ACTUATOR SIZE

- X Manually operated
- 1 Air actuated—small (500 psig max.)
- 2 Air actuated—medium (800 psig max.)
- 3 Air actuated—large (3600 psig max.)

ACTUATOR MATERIAL

- X Manually operated
- 1 316L stainless steel
- 4 Monel®
- 5 Aluminum (standard)
- 6 Hastelloy® C

MAXIMUM PROCESS PRESSURE

- A 250 psig
- B 500 psig
- C 800 psig
- D 3600 psig
- E 2000 psig

INLET CONNECTION TYPE*

- C1 Male Gyrolok® ¼"
- G1 Gyrolok® ¼"
- G2 Gyrolok® ⅜"
- G4 Gyrolok® ¼"
- T6 Gyrolok® 6mm
- T8 Gyrolok® 8mm
- F4 Female NPT ¼"
- M4 Male NPT ¼"
- B4 Female BSP/ISO 7/1 ¼"
- D4 Male BSP/ISO 7/1 ¼"
- X4 Extended, ¼" male NPT
- SM Surface mount (MS³)
- V4 ¼" VCR-compatible swivel female
- R4 ¼" VCR-compatible fixed male
- W4 ¼" tube stub
- S4 ¼" tube socket weld

OPTION

- 0 None
- 1 Cleaned for oxygen service
- 4 Panel mount (manual valves only)
- 6 Panel mount & cleaned for oxygen service (manual valves only)

SEAT MATERIAL

- A Tefzel® (800 psig max.)
- C Polyimide (VespeI®)
- H PCTFE (Kel-F®) (standard)
- Q PEEK™

OUTLET CONNECTION TYPE*

- C1 Male Gyrolok® ¼"
- G1 Gyrolok® ¼"
- G2 Gyrolok® ⅜"
- G4 Gyrolok® ¼"
- T6 Gyrolok® 6mm
- T8 Gyrolok® 8mm
- F4 Female NPT ¼"
- M4 Male NPT ¼"
- B4 Female BSP/ISO 7/1 ¼"
- D4 Male BSP/ISO 7/1 ¼"
- X4 Extended, ¼" male NPT
- SM Surface mount (MS³)
- V4 ¼" VCR-compatible swivel female
- R4 ¼" VCR-compatible fixed male
- W4 ¼" tube stub
- S4 ¼" tube socket weld

* Note with the exception of male NPT and female NPT, inlet and outlet connections must be of the same type.

Gyrolok® is a registered trademark of HOKE Incorporated.
Viton® is a registered trademark of DuPont Dow Elastomers.
VespeI® is a registered trademark of E.I. du Pont de Nemours and Company.
Tefzel® is a registered trademark of the DuPont Company.
Monel® is a registered trademark of Special Metals Corporation.
Hastelloy® is a registered trademark of Haynes International, Inc.
Kel-F® is a registered trademark of 3M Company.
Elgiloy® is a registered trademark of Elgiloy Specialty Metals.
PEEK™ is a trademark of Victrex PLC.

For Your Safety

It is solely the responsibility of the system designer and user to select products suitable for their specific application requirements and to ensure proper installation, operation, and maintenance of these products. Material compatibility, product ratings and application details should be considered in the selection. Improper selection or use of products described herein can cause personal injury or property damage.