

ISOLATE

BALL VALVES

MODEL-BVA1

In Line Valve.

Rated 400 BAR / 6000 PSI

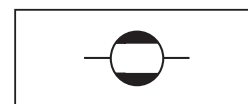

Circuit Diagram

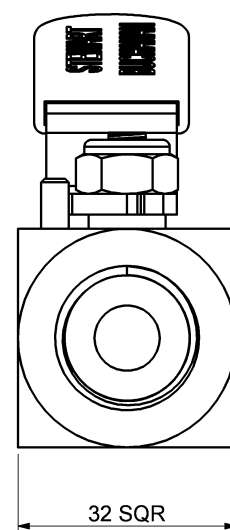
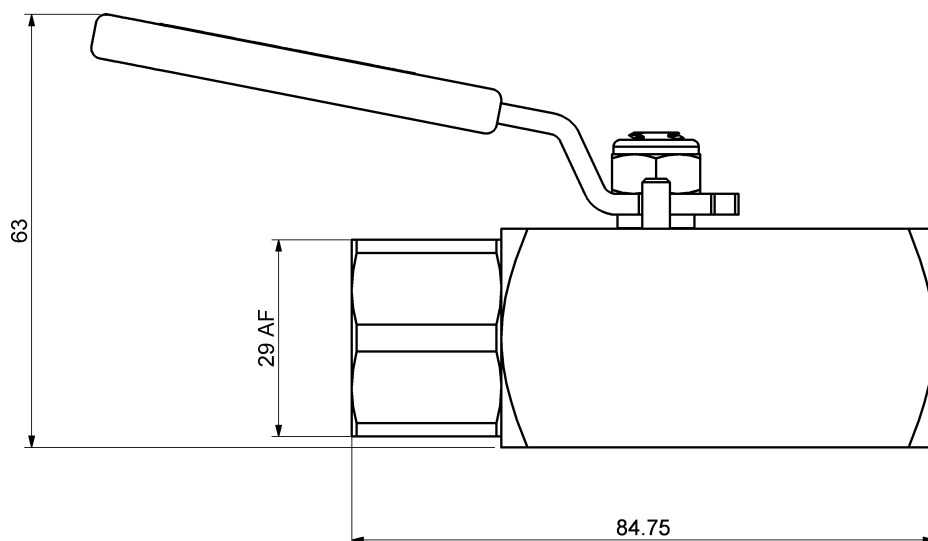

STEWART-BUCHANAN GAUGES LTD
Sales Office & Manufacturing Facility.
Burnside Industrial Estate, Kilsyth, G65 9JX, SCOTLAND
Tel:- +44 (0)1236 821533
Fax:- +44 (0)1236 824090
E-Mail:- sales@stewarts-group.com
Web Site:- www.stewarts-group.com

stewarts-group.com

Pressure Gauges . Thermometers . Needle Valves . Ball Valves . Check Valves . Manifolds