

NEEDLE VALVES

MODEL-A1 M/F

In Line Needle Valve

Rated 400 BAR / 6000 PSI

Male / Female

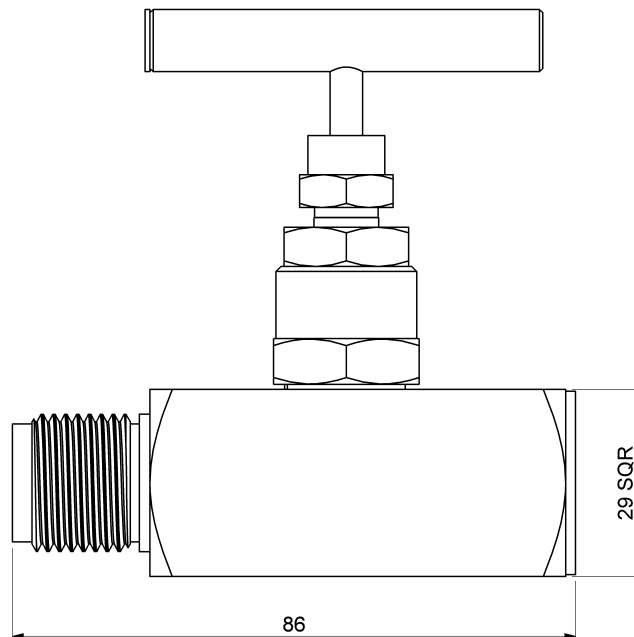
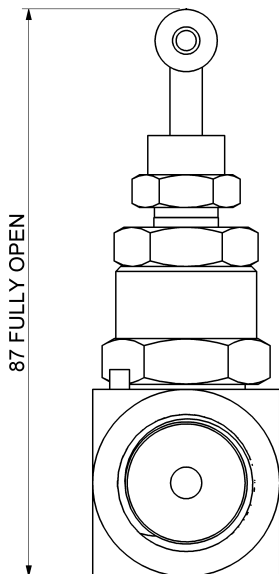
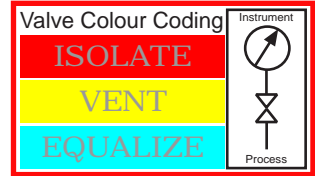

STEWART-BUCHANAN GAUGES LTD

Sales Office & Manufacturing Facility,
Burnside Industrial Estate, Kilsyth, G65 9JX, SCOTLAND

Tel:- +44 (0)1236 821533

Fax:- +44 (0)1236 824090

E-Mail:- sales@stewarts-group.com

Web Site:- www.stewarts-group.com

stewarts-group.com

Pressure Gauges . Thermometers . Needle Valves . Ball Valves . Check Valves . Manifolds