

ANY ANGLE

Stainless Steel Thermometer

TEMPERATURE

Temperature element

- (a) Bi-Metal System
- (b) Inert Gas System

Case

AISI 304 Stainless Steel
Bezel Stainless Steel (Bayonet type).
Weatherproof Construction

Dial

White Aluminium (Black Printing)

Pointer

Black Aluminium

Window

Sheet Glass

Standard Size

100, 125, 150mm

Accuracy class

1% Gas filled
1.5% Bi-Metal

Scale Range

Bi-Metal - 50 up to 600 deg C.
Gas Filled - 100 up to 650deg C.
See standard scale range data sheet.

Stem

Stainless Steel.

Stem Dia

Bi-Metal - 6, 8,10, or 12mm.
G.F - 6,8,10,12, or 12.7 mm.

Ordering information

State:- Temperature gauge model
/ Nominal size / Scale range
/ Stem dia - length / Size of connection
/ Optional extras reqd.



Bi-Metal System
Model - 2050



Optional extras

AISI 316 Stainless Steel Case.
Slot adjustable pointer / Black Finish.
Window laminated Safety Glass / Perspex.
Thermowells per DIN or to user specification.
Additional Variations: on request.

We manufacture a wide range of instruments to customer's special requirements
We shall be pleased to discuss and advise on your specifications.

Specifications and dimensions given in this leaflet represent the state of engineering at the time of printing.
Engineering modifications may take place without prior notice.

STEWART-BUCHANAN GAUGES LTD

Sales Office & Manufacturing Facility.
Burnside Industrial Estate, Kilsyth, G65 9JX, SCOTLAND
Tel:- +44 (0)1236 821533
Fax:- +44 (0)1236 824090
E-Mail:- sales@stewarts-group.com
Web Site:- www.stewarts-group.com

stewarts-group.com

ANY ANGLE

Stainless Steel Thermometer

TEMPERATURE

Standard Dimensions

Gas Filled System
Model - 975

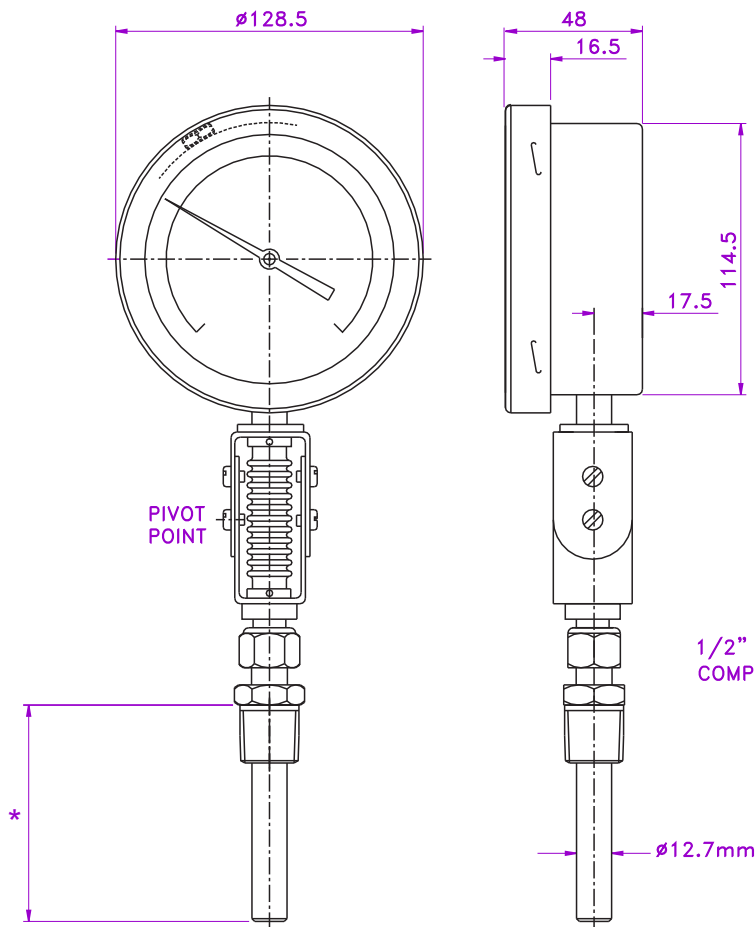

* As specified by the customer

Bi-Metal System
Model - 2050

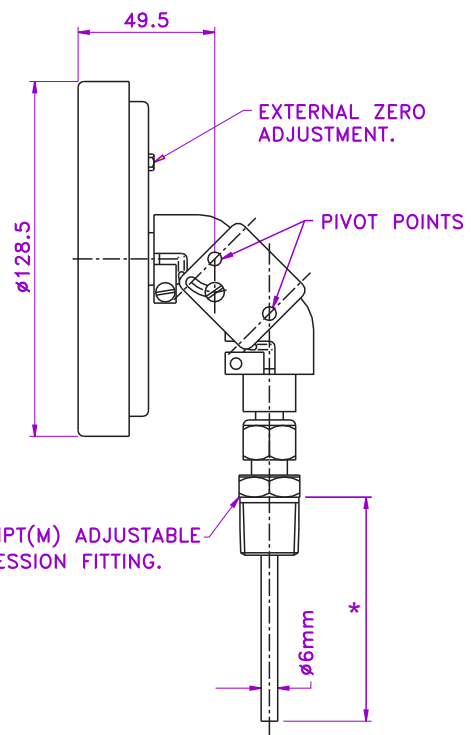

* As specified by the customer

STEWART-BUCHANAN GAUGES LTD
Sales Office & Manufacturing Facility.
Burnside Industrial Estate, Kilsyth, G65 9JX, SCOTLAND
Tel:- +44 (0)1236 821533
Fax:- +44 (0)1236 824090
E-Mail:- sales@stewarts-group.com
Web Site:- www.stewarts-group.com

stewarts-group.com

Pressure Gauges . Thermometers . Needle Valves . Ball Valves . Check Valves . Manifolds