

HIGH FLOW / PURGE

PRESSURE REDUCING REGULATOR

44-3200 SERIES

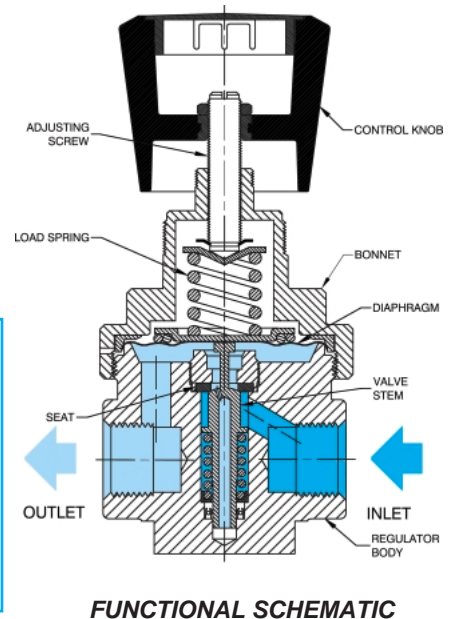
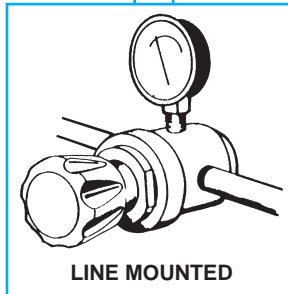

HIGH FLOW ($C_V = 1.0$) • PURGE GAS REGULATOR

The 44-3200 High Flow Regulator is designed as a purge gas regulator and may be used in gas systems involving corrosive or toxic media.

The 44-3200 features a large main valve and a flow capacity of $C_V=1.0$. In the high pressure version, the main valve is balanced to minimize the effect of inlet pressure fluctuations on outlet pressure. The low pressure version utilizes an unbalanced main valve for reliable shutoff.

All wetted (media contact) parts are 316 Stainless Steel (or brass), CTFE and Teflon®. The designed maximum leak rate is 2×10^{-8} atm cc/sec He.

An adjustable stop may be set to limit outlet pressures that meet specific system requirements.

- Design maximum inboard leak rate: 2×10^{-8} atm cc/sec He
- Wetted (media contact) materials are corrosion resistant
- High flow capacity, $C_V=1.0$ ($C_V=1.8$ optional)
- Maximum inlet pressures: 500 and 3,000 PSIG
- Outlet pressure ranges: 5-25, 5-50, 5-100, 5-150, 5-200 PSIG (.3-1.7, .3-3.4, .3-6.9, .3-10.3 and .3-13.8 bar)
- Optional: base mounting, panel mounting, gauge ports, captured bonnet, self venting and dome loading

TYPICAL APPLICATIONS

- High Flow Purging Systems
- Regulating Corrosive Gases and Specialty Gases
- Manifold Regulator
- Research Labs

TESCOM

C O R P O R A T I O N

INDUSTRIAL CONTROLS DIVISION

12616 Industrial Boulevard
Elk River, Minnesota 55330-2491

1-800-447-1250 (612) 241-3238

Fax: (612) 241-3224

e-mail: icd@tescom.com

www.tescom.com

INSTALLATION DIMENSIONS

METRIC EQUIVALENTS ARE IN PARENTHESES
ALL DIMENSIONS ARE REFERENCE ONLY

44-3200 SERIES

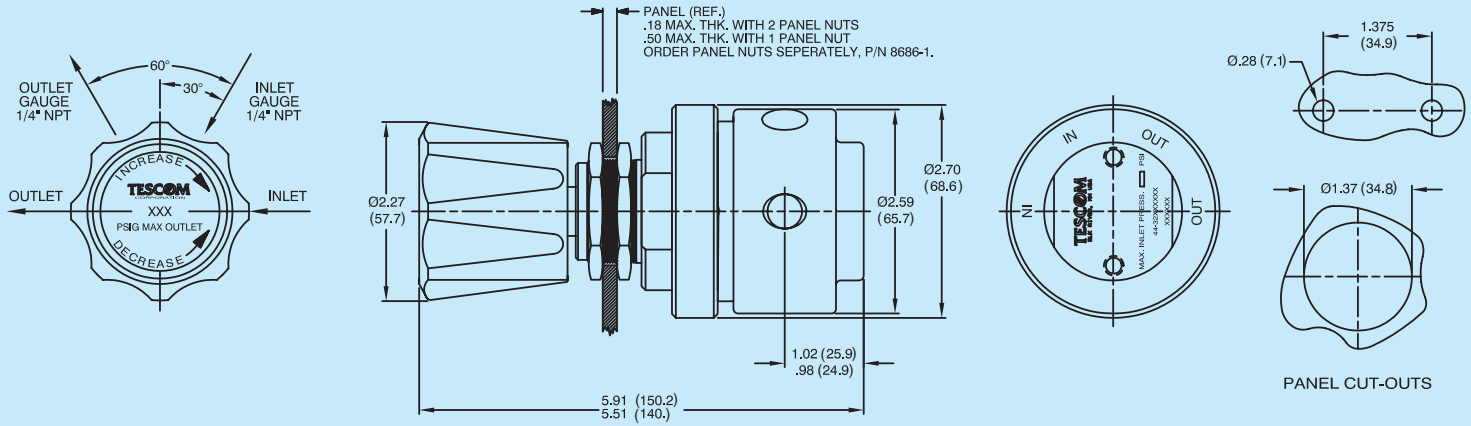

FLOW CHARTS

REGULATOR DISCHARGE CHARACTERISTICS CURVES (metric units are in parentheses)

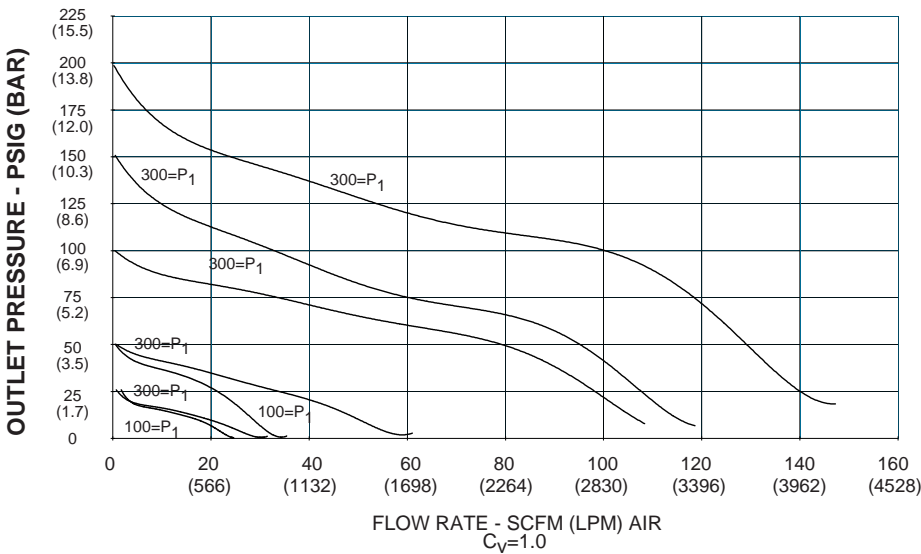
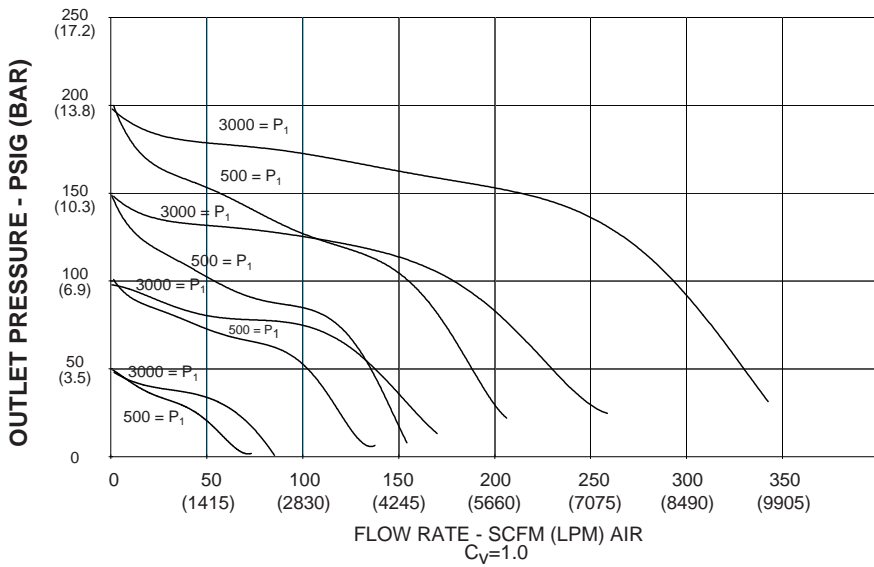

SPECIFICATIONS

FLUID MEDIA -All gases corrosive and non-corrosive or those requiring regulation compatible with materials of construction. For other media, consult factory.*

PRESSURE RATING - Per criteria of ANSI / ASME B31.3.

Maximum rated inlet pressure 500, 3000 PSIG
 (3.4-34.5, 13.8-207 bar)

Outlet pressure ranges 5-25, 5-50, 5-100, 5-150, 5-200 PSIG
 (3-1.7, .3-3.4, .3-6.9, .3-10.3, .3-13.8 bar)

Design proof pressure150% maximum operating pressure

Materials:
 Body 316 Stainless Steel or brass
 Trim 316 Stainless Steel
 Bonnet Nickel plated brass
 Diaphragm 316 Stainless Steel
 Seal Teflon®
 Seat High pressure: CTFE
 Low pressure: Teflon®

Flow capacity C_v = 1.0

Operating temperature-40°F to +165°F (-40°C to +74°C)

Weight (w/o gauges) 3.5 lbs. (1.6 kg)

Standard porting 3/8", 1/2" NPT inlet and outlet,
 1/4" inlet and outlet gauge ports @ 60°

* Tescom may suggest material for use with specific media. Suggestions are based on technical compatibility resources through associations and manufacturers. Tescom does NOT guarantee materials to be compatible with specific media. THIS IS THE RESPONSIBILITY OF THE USER. Users must test under operating conditions to determine suitability of materials in an application.

ACCESSORIES (additional cost)

GAUGES (consult GAUGES section of catalog):

PANEL MOUNTING NUT(S) P/N 8686-1

STANDARD REPAIR KIT for 44-326XJXX1 P/N 389-6855

44-326XHXX3P/N 389-6856

NOTE: Special tools are required for the maintenance of the 44-3200. Consult factory for Repair Kits for regulator modifications.

LEAK RATE CERTIFICATION - To 2x10⁻⁸ atm cc/sec He available at extra cost. Consult factory.

ORDERING INFORMATION

EXAMPLE: 44-3261J281

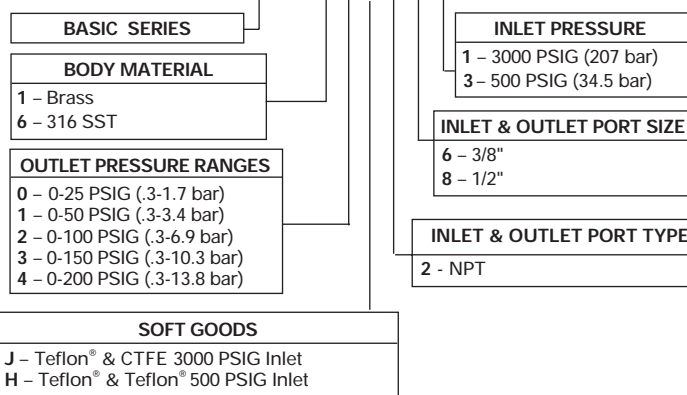

NOTE: Optional 1.8 C_v available at additional cost. Consult factory.

STANDARD CLEANING: 44-3200 regulators are cleaned in accordance with the "intermediate" level of ASTM-G93 and CGA 4.1. The "intermediate" level assures removal of visible particles and combustible residues.

OXYGEN SERVICE: System designers must verify the compatibility of materials used in this product before installation and operation. Specification of materials for oxygen service is the **USER'S RESPONSIBILITY**. Cleaning for oxygen service per the "intermediate" level requirements of ASTM G93 and CGA 4.1 can be supplied by Tescom.

ADJUSTABLE STOP: This regulator incorporates an adjustable stop which allows the maximum outlet pressure to be limited to any value between the maximum rated value and 50% of the maximum rated value.



INDUSTRIAL CONTROLS DIVISION
12616 Industrial Boulevard
Elk River, Minnesota 55330-2491
1-800-447-1250 (612) 241-3238
Fax: (612) 241-3224
e-mail: icd@tescom.com
www.tescom.com